

Gracias por adquirir nuestras pantallas



Todas las pantallas Phoenix son sometidas a una estricta inspección de calidad antes de su entrega. Lea este manual de forma cuidadosa para un uso correcto. También podrá encontrar la solución a distintos problemas que se pudieran presentar.

### 1. Componentes:

#### Parte de adelante

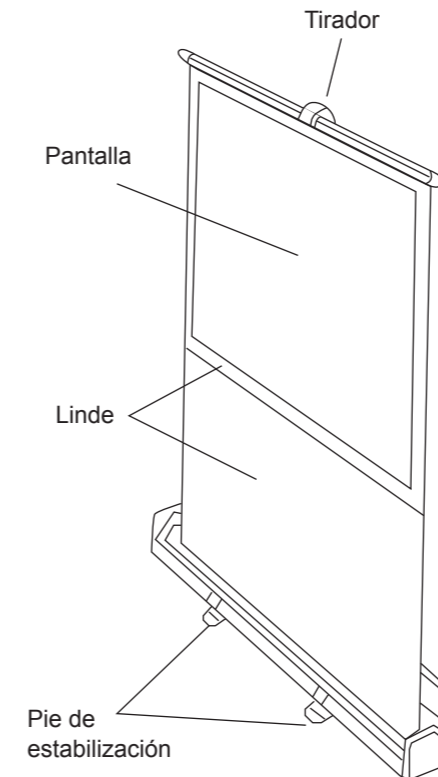

#### Parte de atrás

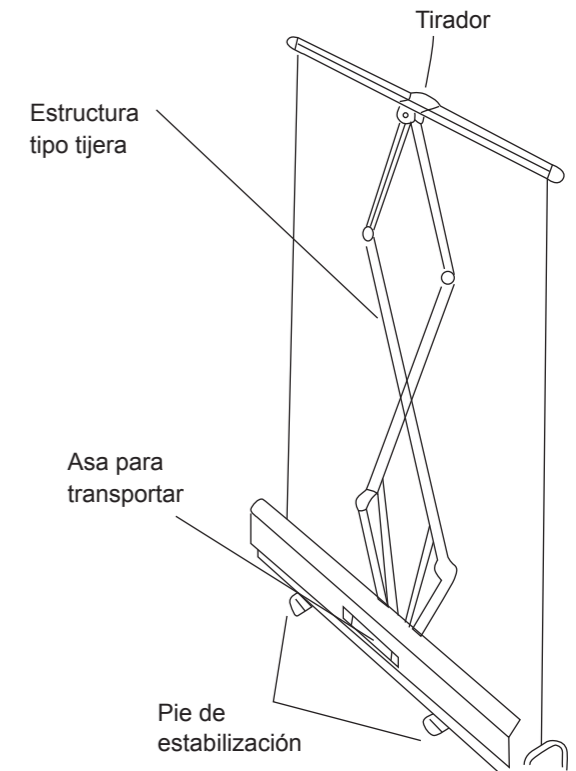

## 2. Detalles y medidas

### Carcasa

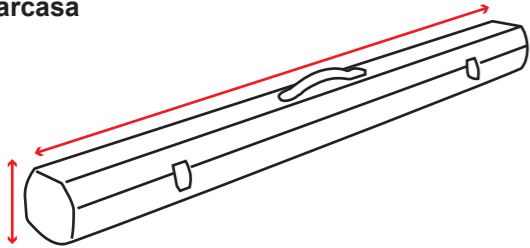

### Carcasa abierta

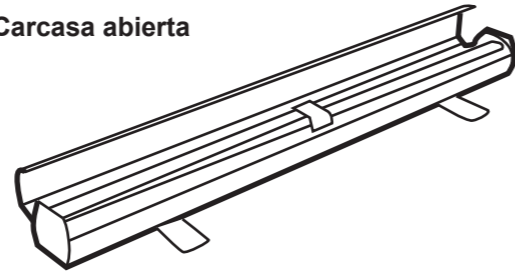

### Medidas Parte delante

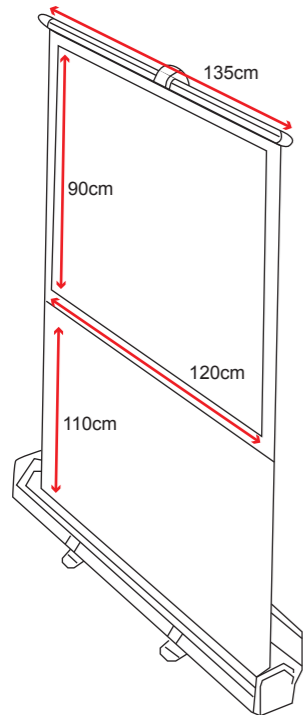

### Detalles

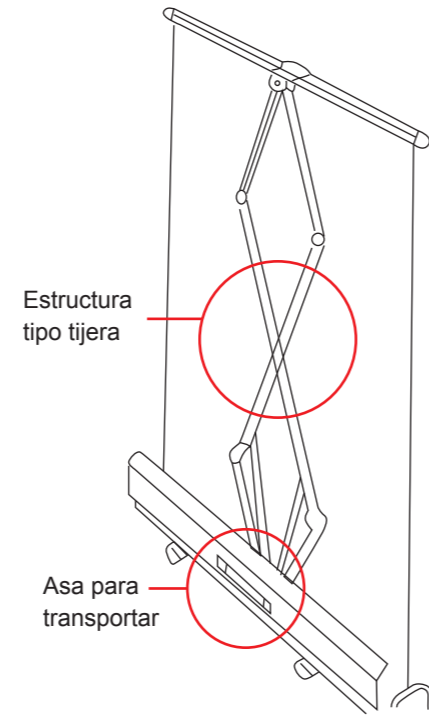

## 3. Instalación.

Saca el pie estabilizador que se encuentra bajo la estructura de la caja transportadora.

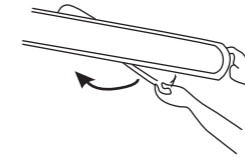

1. Desbloquea los cierres de la caja y ábrela.
2. Tira suavemente hacia arriba del asa de la pantalla hasta que la pantalla alcance la altura deseada.

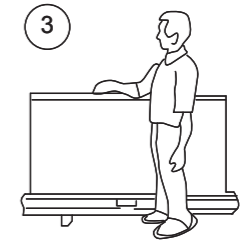
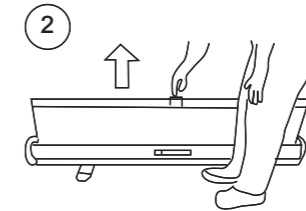
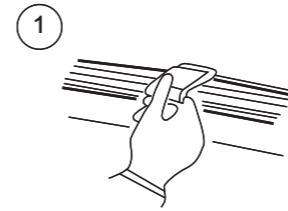

Para bajar de altura la pantalla, tira suavemente hasta alcanzar el tope y suavemente bájala. Siga la pantalla hasta que se introduzca en la caja para evitar que se recoge demasiado rápido y dañarla.

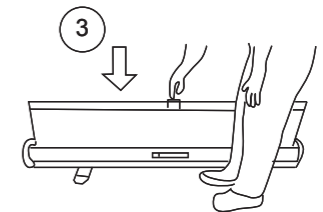
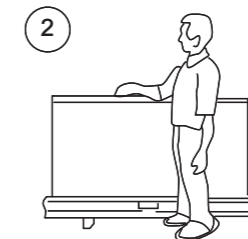
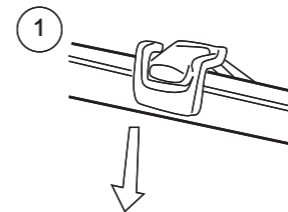

Una vez cerrada, cierra las dos hebillas de la caja e introduce el pie estabilizador dentro de la caja.

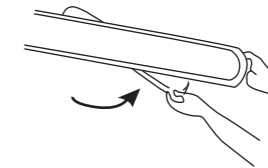
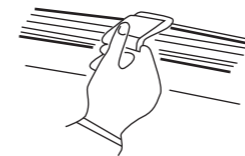

## 4. Seguridad y mantenimiento

- Mantén apartada la pantalla de temperaturas excesivas como estufas, chimeneas o calefactores
- Mantén pantalla fuera del alcance de los niños
- Para mantener la superficie de la pantalla limpia, no la toques con los dedos y guárdala siempre después de su uso.
- Se recomienda abrirla totalmente en su primer uso y ventilarla ya que debido al material usado para su fabricación, esta desprenda algún tipo de olor.



### Precauciones:

#### ADVERTENCIAS DE USO

- No tirar con fuerza al desplegar o recoger la pantalla. Si lo hace, puede dañar el mecanismo de la pantalla.
- La superficie de proyección no debe de ser doblada.
- No tocar la superficie de proyección con los dedos. Puede hundirse.
- No derramar líquidos.
- Mantenerla lejos de objetos con alta temperatura.
- Si la pantalla esta sucia, lávela con una bola de algodón humedecida con agua (no use químicos).
- Después del uso, le recomendamos recogerla. Si no va a ser usada en mucho tiempo, desmóntela y guárdala en su embalaje o caja de cartón.

## GARANTÍA

Muchas gracias por haber adquirido un producto marca Phoenix Technologies.

Esperamos que nuestro producto le proporcione un excelente servicio durante mucho tiempo.

Como fabricantes y responsables del producto que ha adquirido estamos convencidos de la excelente calidad del mismo y esperamos que no tenga necesidad de ninguna intervención técnica durante su tiempo de vida, no obstante en caso de necesitarla puede hacerlo a través del establecimiento donde adquirió el producto o contactando con nuestro Servicio de Atención al cliente en el TLF 902 114 290 o a través de mail [sat@phoenixtechnologies.es](mailto:sat@phoenixtechnologies.es).

### CONDICIONES

La presente garantía ampara a su producto Phoenix Technologies durante un periodo de dos años a partir de la fecha de compra. Deberá ser justificada la fecha de adquisición con factura de compra, ticket o documento con valor fiscal.

La garantía de su producto Phoenix Technologies esta sujeta a la "Ley General de Defensa de Consumidores y Usuarios" según real decreto legislativo 1/2007.

Phoenix Technologies da una garantía comercial limitada sobre las baterías de 6 meses y sobre los transformadores y accesorios de 12 meses a partir de la fecha de compra, por ser considerados como producto fungibles.

Para más información sobre las condiciones de garantía visite nuestra web [www.phoenixtechnologies.es](http://www.phoenixtechnologies.es)

DESIGNED IN EUROPE  
MADE IN P.R.C.



Imported by / Importado por: PHOENIX TECHNOLOGIES SPAIN S.L. CIF: B18314112  
Parque Metropolitano, C/ Los Visos Nº 14 C.P.: 18130 Escúzar, Granada (Spain).  
Designed in Europe, made in P.R.C. / Diseñado en Europa, fabricado en P.R.C.  
Learn more / Más información: [www.phoenixtechnologies.es](http://www.phoenixtechnologies.es)



[www.phoenixtechnologies.es](http://www.phoenixtechnologies.es)

## TARJETA DE GARANTÍA

Por favor, debe complementar este documento para la tramitación de su garantía.

Nº de serie del Producto:

Fecha de compra:

Nombre:

Dirección:

Teléfono:

Distribuidor Autorizado:

Dirección:

Distribuidor:

Sello Distribuidor:



#### 4. Safety and maintenance instructions.

- Do not use this screen near any source of excessive heat, such as a stove, fireplace, or space heater.
- Please keep this screen away from children.
- To help keep the screen's surface clean, avoid touching it with your fingers, and please store in case after use.
- Due to the processes used to manufacture the screen material, there can sometimes be a slight odour when first opened. Although every care is taken to air the products sufficiently, remnants of the odour may remain. Simply leave the screen in the open position in a well-ventilated area for 24-48 hours, and it will dissipate naturally.



#### Precautions:

- Do not pull too forcefully when lowering or rising the screen or damage will result.
- Do not bend the picture surface.
- Do not put pressure on the picture surface with your fingers or it may be damaged.
- Do not spill liquids on the screen.
- Keep it away from objects with high temperatures.
- If the screen gets dirty, use a very soft duster humidified with water to gently remove any foreign particles (do not apply any chemicals).
- Protect Your Screen by keeping it rolled in its protective case when not in use.

#### WARRANTY TERMS

Thank you for purchasing one Phoenix product.

We hope our products will service you with an excellent service for a long time.

As manufacturers, at Phoenix Technologies we are liable to guarantee the first-rate quality of your Product, and so we expect you will not need to ask for technical assistance during the life of your Product. Notwithstanding, should you need technical assistance, you can refer to your vendor or contact our Customer Service by dialing +34 902 114 290 or sending an e-mail to [sat@phoenixtechnologies.es](mailto:sat@phoenixtechnologies.es).

#### · CONDITIONS

The present warranty covers your Phoenix Technologies' product for a limited period of two years upon the date of purchase, which must be proven by a proof with fiscal value such as the original receipt of the purchase or ticket.

The warranty of your Product is subject to the General Law for the Defense of Consumers and Users (Ley General para la Defensa de Consumidores y Usuarios – LCU) by Royal Decree 1/2007.

Phoenix Technologies provides a Limited warranty of six (6) months for all batteries and of 12 months for all transformers and accessories, since they are considered perishable products. The warranty period shall commence upon purchase of the Product by the end user.

For more information on our warranty terms, please visit our website [www.phoenixtechnologies.es](http://www.phoenixtechnologies.es)



Imported by / Importado por: PHOENIX TECHNOLOGIES SPAIN S.L. CIF: B18314112  
Parque Metropolitano, C/ Los Visos Nº 14 C.P.: 18130 Escúzar, Granada (Spain).  
Designed in Europe, made in P.R.C. / Diseñado en Europa, fabricado en P.R.C.  
Learn more / Más información: [www.phoenixtechnologies.es](http://www.phoenixtechnologies.es)



[www.phoenixtechnologies.es](http://www.phoenixtechnologies.es)

#### WARRANTY CARD

In order to proceed with your guarantee terms, please fill in the following card.

Product's serial number:  
Date of purchase:  
Name:  
Address:  
Telephone number:

Vendor:  
Address:  
Distributor:

Distributor's stamp:



## 2. Details and measures

Case

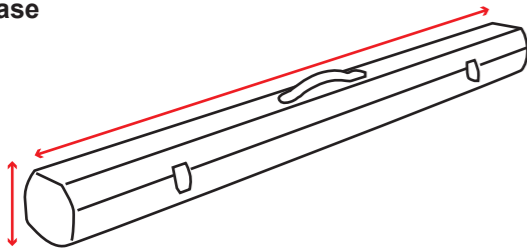

Open housing

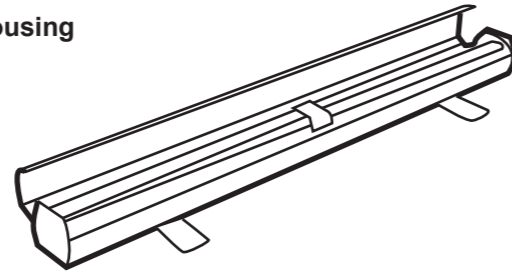

Part front measures

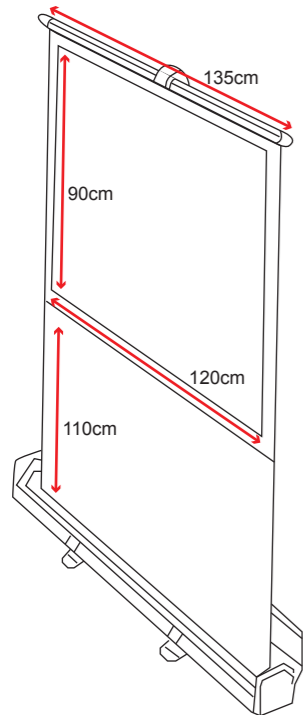

Details

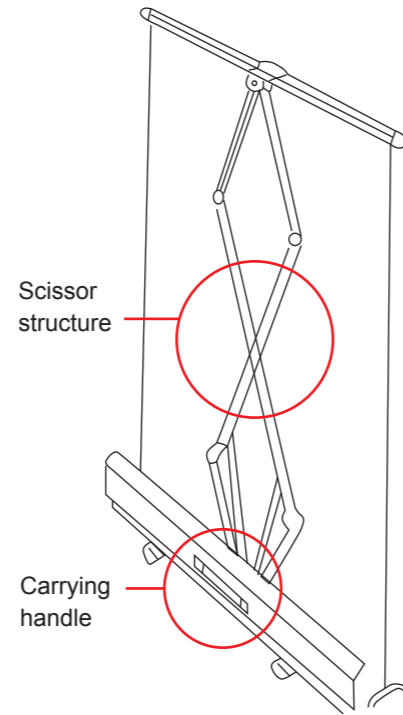

## 3. Operating the screen

Rotate the stabilizing feet out from under the carrying case.

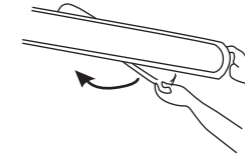

1. Unlock the clasps on the carrying case, and open the case.
2. Grasping the handle of the screen, pull up gently until the screen reaches the desired height.

1

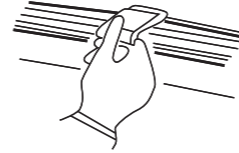

2

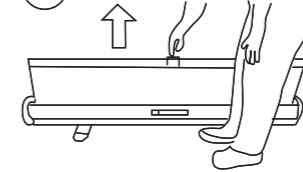

3

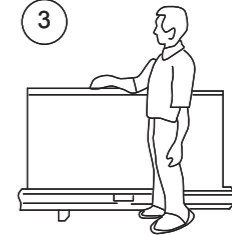

To lower the screen, grasp the top handle and gently push down. Guide the screen back into the case with your hand to prevent it from retracting too quickly.

1

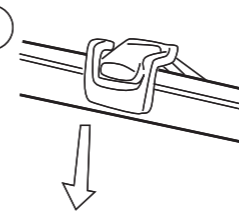

2

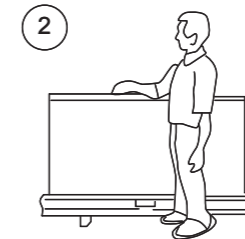

3

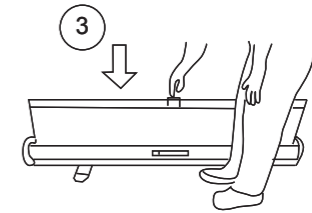

After closing, secure both clasps on the screen's casing and tuck the stabilizing feet under the case.

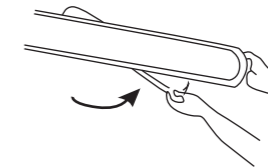
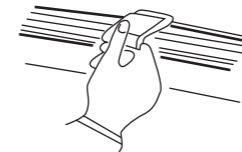



## USER'S MANUAL | MANUAL DE USUARIO

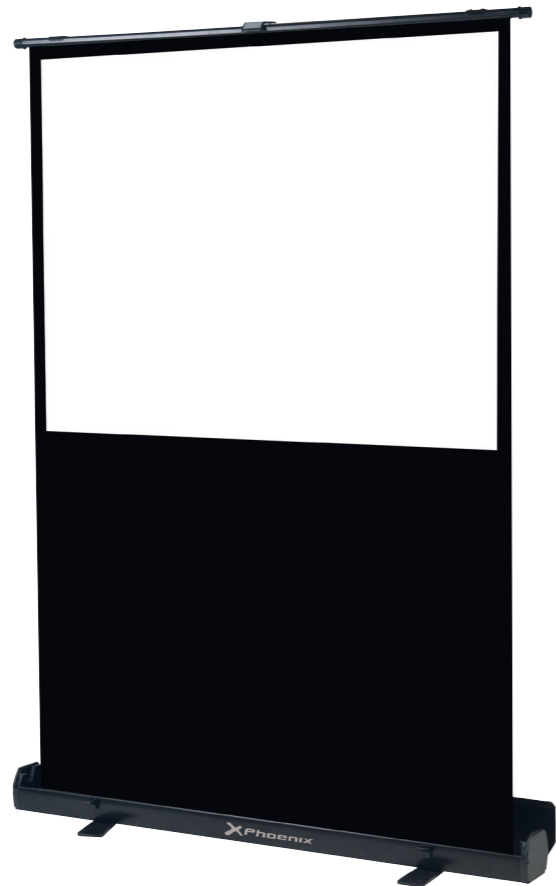

Thank you for purchasing a Phoenix projection screen



All Phoenix projection screens have gone through a thorough quality control inspection before their delivery. Please read this instruction book carefully for a correct use of your projection screen. Similarly, in this manual you will find the answers to different problems that may happen when installing the screen.

### 1. Screen Components:

Front of screen

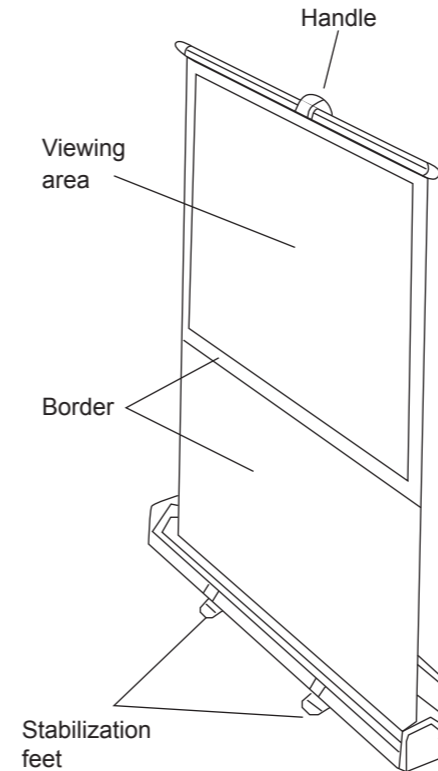

Rear of screen

