

phoenix

RUMBLE

B O^{XL} S S

160W

MANUAL DE USUARIO

USER MANUAL



ESPAÑOL

CONTENIDO

CONTENIDO	2
ESPECIFICACIONES TÉCNICAS	2
PRECAUCIONES DE SEGURIDAD	3
INSTRUCCIONES DE USO DEL PANEL SUPERIOR	3
INSTRUCCIONES DE USO DEL MANDO A DISTANCIA	5
FUNCIONAMIENTO DE LA FUNCIÓN TWS	6
FUNCIONAMIENTO MICRÓFONO INALÁMBRICO	6
INSTRUCCIONES Y FUNCIONAMIENTO BLUETOOTH	7
GARANTÍA	8

ESPECIFICACIONES TÉCNICAS

- POTENCIA: 120W
- IMPEDANCIA: 4 Ω
- SENSIBILIDAD DE ENTRADA: 92 \pm 3 DB
- RESPUESTA EN FRECUENCIA: 55-18K HZ
- RELACIÓN SEÑAL/RUIDO: \geq 70DB
- UNIDAD DE ACCIONAMIENTO: 1"+2X8"
- FRECUENCIA DE MICRÓFONO INALÁMBRICO: 261.8MHZ
- NOMBRE BLUETOOTH: RUMBLEBOSS-XL
- FRECUENCIA FM: 87.50-108.00 MHZ
- VOLTAJE: 100-240V~50-60HZ

PRECAUCIONES DE SEGURIDAD

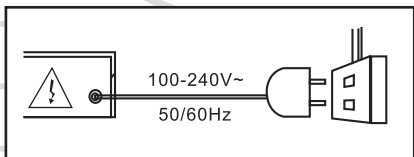

1. POTENCIA

Cuando trabaje/recargue con corriente alterna, hágalo sólo con la potencia indicada en las instrucciones del aparato.

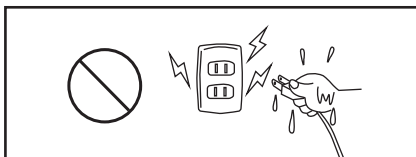

2. PRECAUCIÓN PARA EVITAR DESCARGAS

NUNCA enchufe o desenchufe el aparato con las manos mojadas para evitar descargas eléctricas. No coloque el aparato sobre una zona húmeda o bajo la lluvia o en un lugar donde pueda acumular cualquier líquido en su superficie. No coloque ningún recipiente con agua o cualquier otro líquido encima del aparato.



3. NO LASTRAR CON OBJETOS PESADOS

No coloque ningún objeto encima del aparato. Esta máquina no puede soportar ninguna carga. Evite la luz solar directa y manténgalo alejado de cualquier fuente de calor como estufas, radiadores, etc. No lo instale en ambientes con polvo, altas temperaturas, luces fuertes o campos magnéticos, etc.



4. PROTECCIÓN DE LA LÍNEA ELÉCTRICA

No tire del cable; para desconectarlo de la toma de corriente tire del enchufe. Mantenga el cable de alimentación alejado de lugares donde se pueda pisar, pellizcar o tropezar. No coloque objetos pesados sobre el cable.

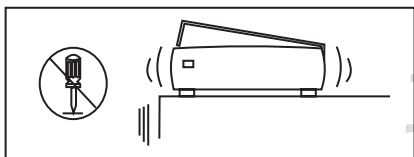

5. NO DESMONTE LA CARCASA

Puede producirse una descarga eléctrica grave si toca las piezas internas del aparato. Evite que caigan piezas metálicas y líquidos en el interior del aparato. aberturas.

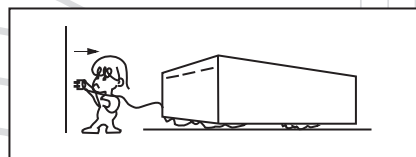

6. PROTECCIÓN DE LA LÍNEA DE ALIMENTACIÓN

Cuando el aparato esté completamente apagado, desconecte el cable de alimentación. el enchufe se utiliza para el dispositivo de desconexión de la alimentación y debe mantenerse en buen estado.

INSTRUCCIONES DE USO DEL PANEL SUPERIOR

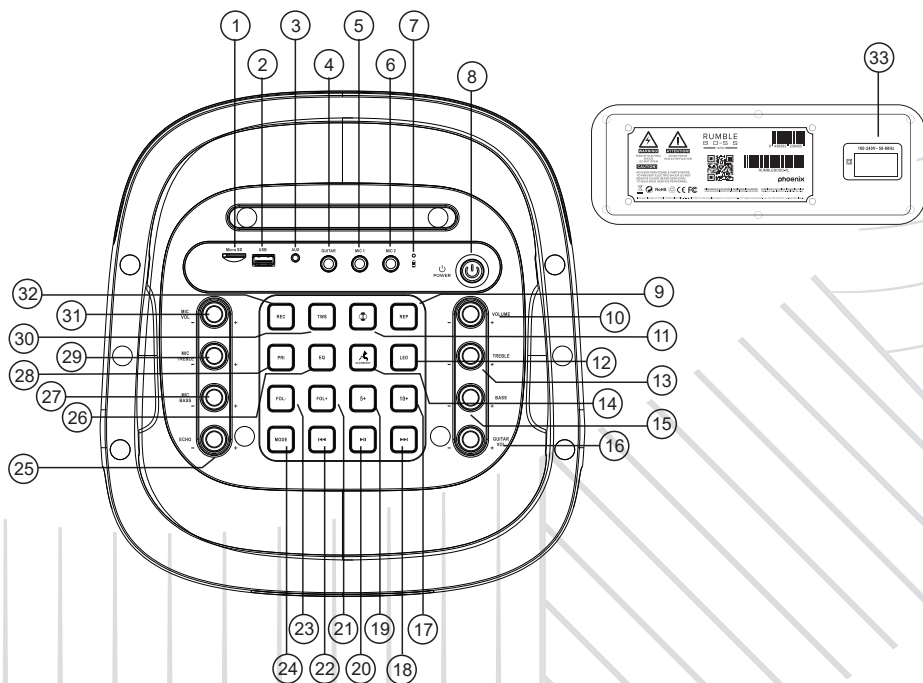

- | | |
|--|---|
| <ol style="list-style-type: none"> 1. Toma Micro SD 2. Toma USB 3. Entrada AUX 4. Entrada de guitarra 5. Entrada MIC1 6. Entrada MIC2 7. Indicador de recarga 8. Encendido/apagado 9. Repetición 10. Control de volumen de música 11. Desconexión Bluetooth 12. Botón de modo de pantalla LED Pulsación corta en varios modos de conversión de pantalla Pulsación larga durante 3 segundos para encender o apagar la luz 13. Control de volumen de agudos 14. Acompañamiento 15. Control de volumen de graves 16. Control de volumen de guitarra | <ol style="list-style-type: none"> 17. 10+ 18. Siguiete y canal FM+ 19. 5+ 20. Reproducir/Pausa y búsqueda FM 21. Folder + 22. Anterior y Canal FM - 23. Folder - 24. Modo de pulsación corta 25. Control de volumen de eco 26. EQ 27. Control de graves del micrófono 28. Prioridad de micrófono 29. Control de agudos del micrófono 30. TWS 31. Control de volumen del micrófono 32. Grabar 33. Entrada de CA 100-240 V 50/60 Hz |
|--|---|

INSTRUCCIONES DE USO DE LOS MANDOS A DISTANCIA

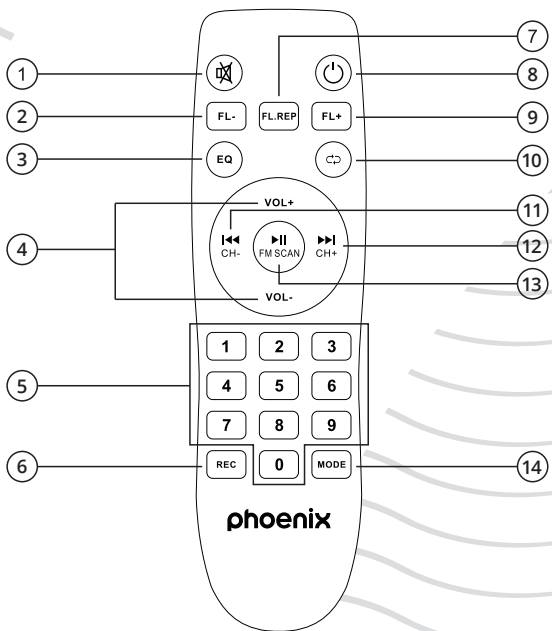

- | | |
|--------------------------|--|
| 1. Silenciar | 8. Espera |
| 2. Folder - | 9. Folder + |
| 3. Modo EQ | 10. Repetir |
| 4. Volumen +/- | 11. Anterior / Canal FM- |
| 5. Selección de pista | 12. Siguiente / Canal FM+ |
| 6. Grabar | 13. Reproducir/Pausa/
Escaneo FM |
| 7. Repetición de carpeta | 14. Modo / Fuente de señal
de entrada |

FUNCIONAMIENTO DE LA FUNCIÓN TWS

TRUE WIRELESS STEREO (TWS) TECHNOLOGY

TWS technology enables user to make wireless connection between two speakers which are same model and compatible with TWS. In TWS connection, two speakers will be automatically grouped to be a Stereo-speaker System which outputs the left and right channel.

HOW TO ESTABLISH

TWS CONNECTION? Reminding: Two speakers must be same model and both compatible with TWS.

1. Please switch on both speakers and select "Bluetooth" Mode;
2. Press the TWS button on the control panel of one of the speakers until you hear a Prompt sound. It becomes the main speaker (left channel), automatically searches for and connects with the other speaker (right channel). After connection, you will hear a Prompt sound
3. Connect your mobile phone or Bluetooth player to the speaker by Bluetooth. After connection, you can play music with the TWS Stereo-speaker System.

TWS MODE MANIPULATIONS In TWS mode, manipulations to the main speaker will be simultaneously effected in the other speaker, for example, volume up and down, previous and next song selection, play and pause, power on and off.

DISCONNECT TWS

Two speakers which were connected by TWS will be automatically reconnected when they are power on and both in Bluetooth mode. Long press TWS button to disconnect two speakers by TWS.

FUNCIONAMIENTO MICRÓFONO INALÁMBRICO

- This product built-in battery, especially suitable for outdoor concert, advertising, entertainment and other activities. Please charge the battery full first before using in outdoor environment. To ensure that the speaker can be used for a long time for outdoor activities.
- To adjust the microphone volume knob to you like when you are demo.
- Please turn off the microphone after using
- Wireless microphone effective distance within 10 meters. In order to not affecting the effect, please do not use over than the valid range. When the battery decreased or the environment radio interference source signal is too strong, it will shorten the using distance.
- To achieve the best effect of singing, the distance of mouth and microphone should be keep in 5-15 cm, and the best angle is 45 degrees.
- Please don't use the same frequency of microphone to sing at the same time in a short distance. It will lead to silence or interference.
- If you buy more than two sets of active speaker with wireless microphones and want to use together at the same time, please select standard frequency of different varieties. If not, there must be 10 meters distance at least between two sets speaker in same frequency. So as not to cause interference and other unnecessary trouble. At the same time, don't put speakers too close to VCD/CD/DVD during using. They are strong interference frequency equipments. In order to avoid mutual interference between the same frequency and directly affects the normal work of the wireless microphone signal receiving.

INSTRUCCIONES

- The battery charges for 8 hours before the first use of this product.
- It must be replaced with batteries of the same specifications when needed, otherwise, the product may not work properly or be damaged.
- To extend battery life, it needs to be charged regardless of the lack of power after each use.
- The charging time depends on the battery specifications. The charging scheme (or the power supply voltage is unstable) is generally 8-16 hours.
- Please keep away from the product more than 2 meters from CRT display or television, because of the speaker magnet field is strong, magnetic interference causes display magnetization or discoloration phenomenon.

FUNCIONAMIENTO BLUETOOTH

FIRST CONNECTION OF BLUETOOTH WITH CELLPHONE

1. Turn the power on, press the "MODE" key or "INPUT" key on the panel or remote control, and switch the speaker to Bluetooth channel. Then turn on the mobile phone Bluetooth function.
2. Search the Bluetooth device list and select the Bluetooth name "RUMBLEBOSS". The speaker will make a notification tone when the connection is successful.
3. Select the Bluetooth which is on Bluetooth device list.

Open the mobile phone music player and play a song. The music is transferred via Bluetooth and sound comes out through the Bluetooth speaker.

CONNECT TO THE MOBILE PHONE WHICH ALREADY BEEN CONNECTED BEFORE.

When the mobile phone Bluetooth is turned on, press the "MODE" and select to Bluetooth mode, the Bluetooth speaker will automatically connect to the mobile phone which is connected last time. Another way is that you can search the Bluetooth list on your mobile phone, when you find the "RUMBLEBOSS", select it and connect your mobile phone to the Bluetooth speaker.

GARANTÍA

DECLARACIÓN DE CONFORMIDAD

Declaramos que el producto mencionado anteriormente cumple con todos los requisitos básicos descritos en la Directiva (2014/30/UE), (2014/35/UE) y (2014/53/UE) del Parlamento Europeo y del Consejo.

Así mismo, se certifica que cumple la Directiva RoHS (2015/863EU) sobre restricciones a la utilización de determinadas sustancias peligrosas en aparatos eléctricos y electrónicos.

Empresa:

PHOENIX TECHNOLOGIES SPAIN C.E.S., S.L

Parque Tecnológico Ogjares,

C/ La Coruña Nº 16

Fecha: Granada, 20 de agosto de 2021

Nombre: Juan Francisco Sáez

Título: Administrador.



GARANTÍA

Muchas gracias por haber adquirido un producto marca Phoenix Technologies. Esperamos que nuestro producto te proporcione un excelente servicio durante mucho tiempo.

Como fabricantes y responsables del producto que has adquirido estamos convencidos de la excelente calidad del mismo y esperamos que no tengas necesidad de ninguna intervención técnica durante su tiempo de vida, no obstante en caso de necesitarla puedes hacerlo a través del establecimiento donde adquiristes el producto o contactando con nuestro Servicio de Atención al cliente en el TLF 902 114 290 o a través de mail sat@phoenixtechnologies.es

CONDICIONES

La presente garantía ampara a tu producto Phoenix Technologies durante un periodo de tres años a partir de la fecha de compra. Deberá ser justificada la fecha de adquisición con factura de compra, ticket o documento con valor fiscal.

La garantía de tu producto Phoenix Technologies está sujeta a la "Ley General de Defensa de Consumidores y Usuarios" según real decreto legislativo 1/2007.

Phoenix Technologies da una garantía comercial limitada sobre las baterías de 6 meses y sobre los transformadores y accesorios de 12 meses a partir de la fecha de compra, por ser considerados como producto fungibles.

Para más información sobre las condiciones de garantía visita nuestra web www.phoenixtechnologies.es.

TARJETA DE GARANTÍA

Por favor, debes complementar este documento para la tramitación de tu garantía.

Nº DE SERIE DEL PRODUCTO:

FECHA DE COMPRA:

NOMBRE:

DIRECCIÓN:

TELÉFONO:

DISTRIBUIDOR:

DIRECCIÓN DEL DISTRIBUIDOR:

SELLO DISTRIBUIDOR:



phoenix

DISEÑADO EN EUROPA | DESIGNED IN EUROPE
FABRICADO EN CHINA | MADE IN CHINA



Imported by / Importado por:
PHOENIX TECHNOLOGIES SPAIN C.E.S., S.L CIF: B18810119
Parque Tecnológico Ogijares,
C/ La Coruña Nº 16 C.P.: 18151 Ogijares, Granada (Spain).
Learn more / Más información: www.phoenixtechnologies.es



FC RoHS



ENGLISH

CONTENT

CONTENT	12
TECHNICAL SPECIFICATIONS	12
SAFETY PRECAUTIONS	13
TOP PANELS OPERATING INSTRUCTIONS	14
OPERATING INSTRUCTIONS FOR REMOTE CONTROLLERS	15
TWS FUNCTION OPERATION	16
OPERATION WIRELESS MICROPHONE	16
INSTRUCTION & BLUETOOTH OPERATION	17
WARRANTY	18

TECHNICAL SPECIFICATIONS

- POWER: 120W
- IMPEDANCE: 4 Ω
- INPUT SENSITIVITY: 92 \pm 3 DB
- FREQUENCY RESPONSE: 55-18K HZ
- S/N RATIO: \geq 70DB
- DRIVE UNIT: 1"+2X8"
- WIRELESS MIC FREQUENCY: 261.8MHZ
- BLUETOOTH NAME: RUMBLEBOSS-XL
- FM FREQUENCY: 87.50-108.00 MHZ
- VOLTAGE: 100-240V~50-60HZ

SAFETY PRECAUTIONS

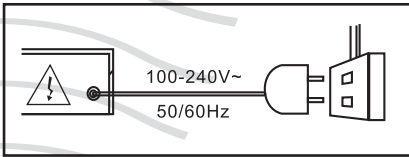

1. POWER

When working/recharging under AC power, please operate only under the power indicated on the instructions marked on the device.

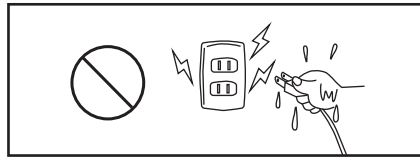

2. CAUTION TO AVOID ELECTRICAL SHOCKS

NEVER plug or unplug the device with wet hands to avoid electrical shock. Do not place the device on a wet area or under the rain or in a place where it can collect any liquid on its surface. Do not place any container with water or any other liquid on top of the device.



3. DO NOT BALLAST HEAVY OBJECTS

Do not place any items on top of the device. This machine cannot bear any load. Avoid direct sunlight and keep it away from any heating source as stoves, radiators, etc. Do not install in environments with dust, high temperatures, strong lights or magnetic fields, etc.

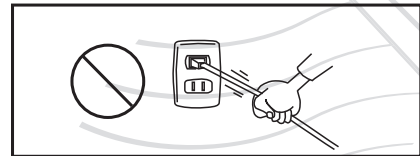

4. POWER LINE PROTECTION

Do not pull the cord; to disconnect from the electrical outlet pull the plug. Keep the power cord away from places where it could be stepped on, pinched, or tripped over. Do not place any heavy objects over the cord.

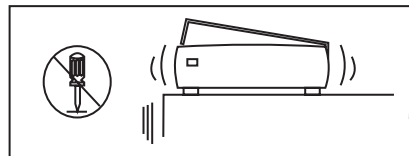

5. DO NOT DISMANTLE THE CASE

Serious electric shock may occur if you touch internal parts of the device. Prevent any metal pieces and liquids from dropping inside the device openings.

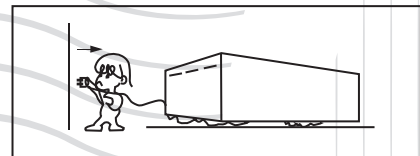

6. POWER LINE PROTECTION

When the unit is completely powered off, please disconnect the power cord, the plug is used for the power cut-off device and must be kept easy to operate.

OPERATING INSTRUCTIONS OF THE TOP PANEL

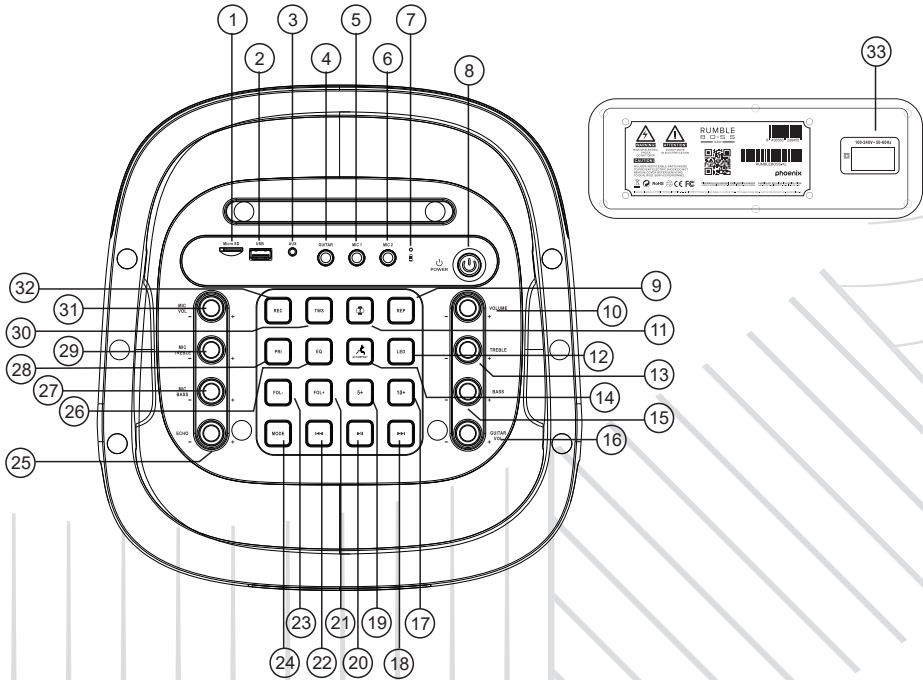

- | | |
|---|---|
| <ul style="list-style-type: none"> 1. Micro SD jack 2. USB jack 3. AUX input 4. Guitar input 5. MIC1 input 6. MIC2 input 7. Recharging indicator 8. Power ON/OFF 9. Repeat 10. Music volume control 11. Bluetooth cut off 12. LED display mode button Short press in various display mode conversion Long press for 3 seconds to switch on or off the light 13. Treble volume control 14. Accompany 15. Bass volume control 16. Guitar volume control | <ul style="list-style-type: none"> 17. 10+ 18. Next & FM channel + 19. 5+ 20. Play/Pause & FM scan 21. Folder+ 22. Previous & FM channel - 23. Folder- 24. Short press mode 25. Echo volume control 26. EQ 27. Microphone Bass control 28. Microphone priority 29. Microphone Treble control 30. True Wireless Stereo 31. Microphone volume control 32. Record 33. AC Input 100-240V 50/60Hz |
|---|---|

OPERATING INSTRUCTIONS FOR REMOTE CONTROLLERS

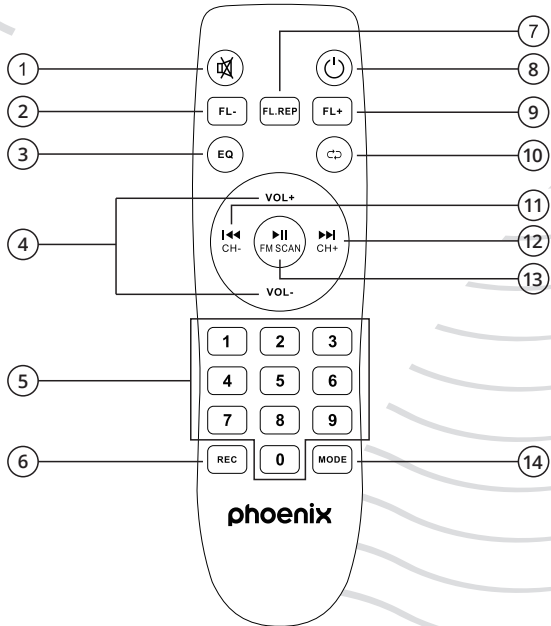

- | | |
|--------------------|--------------------------------|
| 1. Mute | 8. Standby |
| 2. Folder - | 9. Folder + |
| 3. EQ Mode | 10. Repeat |
| 4. Volume +/- | 11. Previous / FM channel- |
| 5. Track selection | 12. Next / FM channel+ |
| 6. Record | 13. Play/Pause/FM scan |
| 7. Folder repeat | 14. Mode / Input Signal Source |

TWS FUNCTION OPERATION

TRUE WIRELESS STEREO (TWS) TECHNOLOGY

TWS technology enables user to make wireless connection between two speakers which are same model and compatible with TWS. In TWS connection, two speakers will be automatically grouped to be a Stereo-speaker System which outputs the left and right channel.

HOW TO ESTABLISH

TWS CONNECTION? Reminding: Two speakers must be same model and both compatible with TWS.

1. Please switch on both speakers and select "Bluetooth" Mode;
2. Press the TWS button on the control panel of one of the speakers until you hear a Prompt sound. It becomes the main speaker (left channel), automatically searches for and connects with the other speaker (right channel). After connection, you will hear a Prompt sound
3. Connect your mobile phone or Bluetooth player to the speaker by Bluetooth. After connection, you can play music with the TWS Stereo-speaker System.

TWS MODE MANIPULATIONS In TWS mode, manipulations to the main speaker will be simultaneously effected in the other speaker, for example, volume up and down, previous and next song selection, play and pause, power on and off.

DISCONNECT TWS

Two speakers which were connected by TWS will be automatically reconnected when they are power on and both in Bluetooth mode. Long press TWS button to disconnect two speakers by TWS.

OPERATION WIRELESS MICROPHONE

- This product built-in battery, especially suitable for outdoor concert, advertising, entertainment and other activities. Please charge the battery full first before using in outdoor environment. To ensure that the speaker can be used for a long time for outdoor activities.
- To adjust the microphone volume knob to you like when you are demo.
- Please turn off the microphone after using
- Wireless microphone effective distance within 10 meters. In order to not affecting the effect, please do not use over than the valid range. When the battery decreased or the environment radio interference source signal is too strong, it will shorten the using distance.
- To achieve the best effect of singing, the distance of mouth and microphone should be keep in 5-15 cm, and the best angle is 45 degrees.
- Please don't use the same frequency of microphone to sing at the same time in a short distance. It will lead to silence or interference.
- If you buy more than two sets of active speaker with wireless microphones and want to use together at the same time, please select standard frequency of different varieties. If not, there must be 10 meters distance at least between two sets speaker in same frequency. So as not to cause interference and other unnecessary trouble. At the same time, don't put speakers too close to VCD/CD/DVD during using. They are strong interference frequency equipments. In order to avoid mutual interference between the same frequency and directly affects the normal work of the wireless microphone signal receiving.

INSTRUCTIONS

- The battery charges for 8 hours before the first use of this product.
- It must be replaced with batteries of the same specifications when needed, otherwise, the product may not work properly or be damaged.
- To extend battery life, it needs to be charged regardless of the lack of power after each use.
- The charging time depends on the battery specifications. The charging scheme (or the power supply voltage is unstable) is generally 8-16 hours.
- Please keep away from the product more than 2 meters from CRT display or television, because of the speaker magnet field is strong, magnetic interference causes display magnetization or discoloration phenomenon.

BLUETOOTH OPERATION

FIRST CONNECTION OF BLUETOOTH WITH CELLPHONE

1. Turn the power on, press the "MODE" key or "INPUT" key on the panel or remote control, and switch the speaker to Bluetooth channel. Then turn on the mobile phone Bluetooth function.
2. Search the Bluetooth device list and select the Bluetooth name "RUMBLEBOSS". The speaker will make a notification tone when the connection is successful.
3. Select the Bluetooth which is on Bluetooth device list.

Open the mobile phone music player and play a song. The music is transferred via Bluetooth and sound comes out through the Bluetooth speaker.

CONNECT TO THE MOBILE PHONE WHICH ALREADY BEEN CONNECTED BEFORE.

When the mobile phone Bluetooth is turned on, press the "MODE" and select to Bluetooth mode, the Bluetooth speaker will automatically connect to the mobile phone which is connected last time. Another way is that you can search the Bluetooth list on your mobile phone, when you find the "RUMBLEBOSS", select it and connect your mobile phone to the Bluetooth speaker.

WARRANTY

DECLARATION OF CONFORMITY

We declare that the above mentioned product complies with all the basic requirements described in Directive (2014/30/EU), (2014/35/EU) and (2014/53/EU) of the European Parliament and of the Council.

Likewise, it is certified that it complies with the RoHS Directive (2015/863EU) on the restriction of the use of certain hazardous substances in electrical and electronic equipment.

Company:

PHOENIX TECHNOLOGIES SPAIN C.E.S., S.L

Parque Tecnológico Ogjares,

C/ La Coruña N° 16

Date: Granada, August 20, 2021

Name: Juan Francisco Sáez

Title: Administrator.



WARRANTY

Thank you very much for purchasing a Phoenix Technologies branded product. We hope that our product will provide you with an excellent service for a long time.

As manufacturers and responsible for the product you have purchased we are convinced of its excellent quality and we hope that you will not need any technical intervention during its lifetime, however in case you need it you can do it through the establishment where you purchased the product or by contacting our Customer Service at TLF 902 114 290 or via mail sat@phoenixtechnologies.es.

CONDITIONS

This warranty covers your Phoenix Technologies product for a period of three years from the date of purchase. The date of purchase must be justified with purchase invoice, ticket or document with fiscal value.

The warranty of your Phoenix Technologies product is subject to the "Ley General de Defensa de Consumidores y Usuarios" according to royal legislative decree 1/2007.

Phoenix Technologies gives a limited commercial warranty on batteries of 6 months and on transformers and accessories of 12 months from the date of purchase, as they are considered as consumable products.

For more information about warranty conditions visit our website www.phoenixtechnologies.es.

WARRANTY CARD

Please complete this document for the processing of your warranty.

PRODUCT SERIAL NO:

DATE OF PURCHASE:

NAME:

ADDRESS:

PHONE:

DISTRIBUTOR:

DISTRIBUTOR'S ADDRESS:

DISTRIBUTOR STAMP:



phoenix

DISEÑADO EN EUROPA | DESIGNED IN EUROPE
FABRICADO EN CHINA | MADE IN CHINA



Imported by / Importado por:
PHOENIX TECHNOLOGIES SPAIN C.E.S., S.L CIF: B18810119
Parque Tecnológico Ogijares,
C/ La Coruña N° 16 C.P.: 18151 Ogijares, Granada (Spain).
Learn more / Más información: www.phoenixtechnologies.es







phoenix

RUMBLE
B O^{XL} S S
— 160W —

phoenix

DISEÑADO EN EUROPA | DESIGNED IN EUROPE
FABRICADO EN CHINA | MADE IN CHINA



Imported by / Importado por:
PHOENIX TECHNOLOGIES SPAIN C.E.S., S.L CIF: B18810119
Parque Tecnológico Ogijares,
C/ La Coruña N° 16 C.P.: 18151 Ogijares, Granada (Spain).
Learn more / Más información: www.phoenixtechnologies.es



FC RoHS